

The Phaserunner V6 Motor Controller

User Manual – Rev 1



Grin Technologies Ltd
Vancouver, BC, Canada

ph: (604) 569-0902
email: info@ebikes.ca
web: www.ebikes.ca

Copyright © 2023

Table of Contents

1 Introduction.....	1
2 Connectors.....	2
2.1 Battery Power.....	2
2.2 Motor Cable – L10 Model.....	2
2.3 Motor Cable – MT Model.....	3
2.4 Cycle Analyst WP8 Plug.....	3
2.5 Mains Signals Plug.....	4
2.6 PAS / Torque Plug.....	4
2.7 Communication Port.....	4
3 Wiring Strategies.....	5
3.1 Cycle Analyst Based Hookup.....	5
3.2 3rd Party Display Hookup.....	5
3.3 Headless System.....	6
4 Controller Mounting.....	7
5 Parameter Tuning	7
5.1 Importing Default Motor Parameters.....	8
5.2 Motor Autotune.....	9
5.3 Battery Limits.....	13
5.4 Motor Phase Current and Power Settings.....	13
5.5 Tuning the Sensorless Self Start.....	15
5.6 Throttle and Regen Voltage Maps.....	16
5.7 Field Weakening for Speed Boost.....	17
5.8 Virtual Electronic Freewheeling.....	18
5.9 Motor Temperature Sensing.....	18
6 Additional Details:	19
6.1 Signal Mapping.....	19
6.2 Reverse Mode.....	20
6.3 Wheel Speed Sensing.....	20
6.4 Combined Temp / Speed Signal.....	21
6.5 Independent Regenerative Braking.....	21
7 Cycle Analyst Settings.....	22
8 LED Flash Codes.....	23
9 Specifications.....	25

1 Introduction

Thank you for purchasing the Phaserunner V6 motor controller based on Accelerated Systems Inc. (ASI)'s BAC800 device.

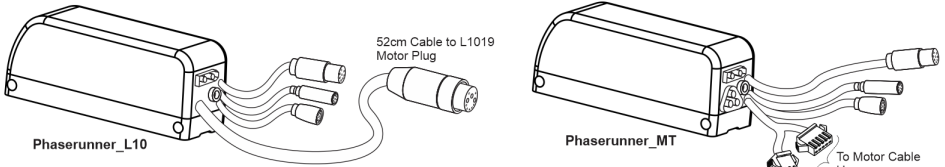

This manual covers two production models: the Phaserunner V6_L10 and the Phaserunner V6_MT. The L10 model is intended for motors already using the L1019 connector, while the MT model employs a cable harness between the controller and motor for accommodating various other connector standards.

Features of the Phaserunner V6 include:

- Compact form factor
- User programmable parameters for customized tuning
- Wide operating voltage (24V - 72V nominal batteries)
- Compatible with both Cycle Analyst and 3rd party displays*
- Supports throttle, PAS and torque sensor control*
- Waterproof design with potted electronics
- Proportional and powerful regenerative braking
- Smooth and quiet field-oriented drive
- Supports thermal rollback in thermistor-equipped motors
- Remote forwards/reverse input
- Field weakening to boost top speed
- Sensorless operation with high eRPM motors

Unlike standard trapezoidal or sine wave controllers, the Phaserunner V6 is a field oriented controller that must be tuned to your motor, battery, and performance requirements for proper operation. This process is detailed in Section 5 Parameter Tuning .

*3rd party display and native PAS integration currently available to OEMs only, not yet supported at the retail level.

2 Connectors

The controller has been connectorized to achieve maximum versatility with minimal wiring, using a combination of waterproof over-molded ebike plugs for signals and popular compact connectors for high current.

2.1 Battery Power

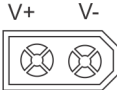
 <p style="text-align: center;">DC Power Pinout</p>	<p>The embedded plug on the back of the device provides a reliable hookup to DC battery power through the compact and popular XT60 plug interface.</p> <p>An 80cm XT60 to Anderson cable is provided with each device to match the Anderson standard used on many ebike batteries.</p>
---	--

- Warning - The controller may suffer irreparable damage if leads are hooked up in reverse polarity. Always check the polarity of the connector before applying power.

2.2 Motor Cable - L10 Model

The L10 model has a 53cm lead to a HiGo L1019 connector for direct hookup to a compatible motor. This length is sufficient to reach a rear hub motor with the controller mounted on the seat-tube, or to a front hub motor with the controller on the stem. Both 60cm and 100cm L10 extension cables are available when longer lengths are required.

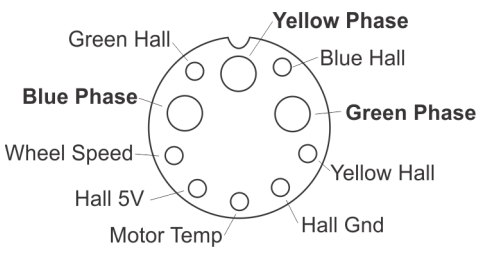

 <p style="text-align: center;">L10 (Female) Motor Plug Pinout</p>	<p>The HiGo L1019 cable has three motor phase pins, along with 7 small signal wires for Hall position, speed encoder, and motor temperature.</p>
---	--

2.3 Motor Cable - MT Model

The motor connection on the MT model uses an MT60 plug for the 3 phase power, and both 5 pin and 3 pin JST-SM plugs for Hall sensor and temp/speed signals. These leads coming from the controller are short, with an expectation that a separate cable harness will be employed to reach the motor terminals.

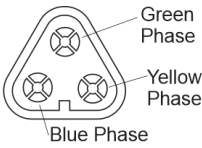
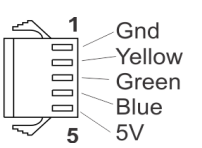
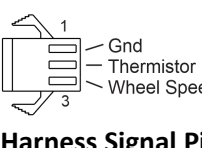
 <p>Motor Harness Phase Pinout</p>  <p>Motor Harness Hall Pinout</p>  <p>Motor Harness Signal Pinout</p>	<p>The MT60 connector supports 3 phase power in a single plug. These connectors can be readily soldered for making custom harnesses.</p> <p>The 3 Hall signals and 5V Hall power are provided through the 5 pin female JST-SM connector. This is a user crimpable plug.</p> <p>If the motor has a temperature and/or wheel speed sensor, these signals can be passed to the controller via the 3-pin plug. Both of these signals must be referenced to the Hall ground pin.</p>
--	---

2.4 Cycle Analyst WP8 Plug

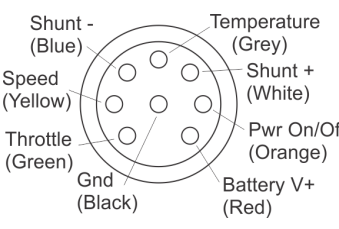
 <p>WP8 (Female) CA3-WP Pinout</p>	<p>The connector for the Cycle Analyst cable uses the waterproof 8-pin Z812 HiGo standard.</p> <p>This connector taps into the controller's shunt resistor for analog current and power sensing, passing through the motor's speed and temperature signals as well. Power modulation of the motor is achieved via the analog throttle line.</p>
---	---

2.5 Mains Signals Plug

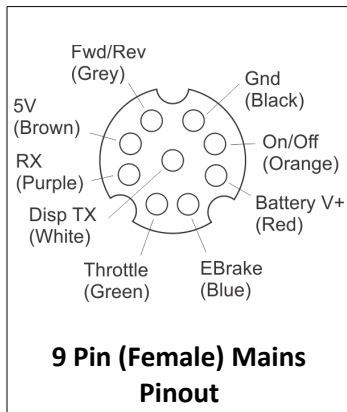

An alternate interface is provided via the 9 pin Mains cable. This uses the Signal D 1109 Connector from Cusmade, and supports conventional ebike wiring strategies for 3rd party display consoles. It shares many signals with the CA-WP plug, but rather than using the shunt resistor for current sensing, it has TX and RX pins that communicate digitally to the display.

2.6 PAS / Torque Plug

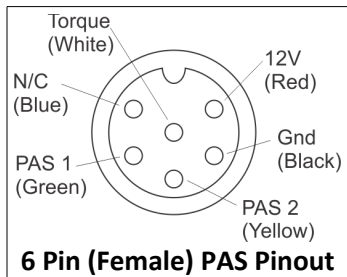

Finally there is a 6 pin HiGo MiniB Z609 plug for connection of a PAS sensor or Torque Sensor.

Note that the **PAS 2** pin shares the same signal as the **Fwd/Rev** input of the Mains cable, and can be configured for either function. (See section 6.3)

2.7 Communication Port

A TRRS jack embedded in the controller can be used for connecting to a computer, Android smart phone, or potential Bluetooth dongle (future product).

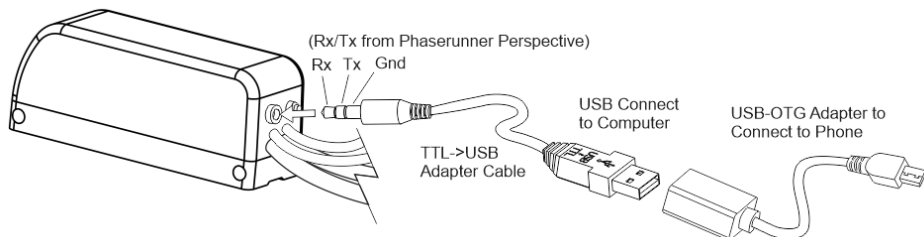

The communication standard uses a 0 to 5V level serial bus. Grin produces a 3m long TTL->USB adapter cable to connect the unit with the USB port of a standard computer. This is the same communication cable used with the *Cycle Analyst*

and *Satiator* products. Third party USB->Serial cables, such as FTDI's part number TTL-232R-5V-AJ are also compatible.

An additional USB-OTG adapter is needed when connecting to an Android smartphone via the phone's smaller Micro USB or USB-C port.

3 Wiring Strategies

The Phaserunner V6 can be hooked up to the controls of an ebike system in one of three ways. It can be connected under the full control of a V3 Cycle Analyst, under the control of a 3rd party display, or "headless" with no display at all.

3.1 Cycle Analyst Based Hookup

The setup using the latest V3 Cycle Analyst (CA3-WP) provides the most versatility with mode presets, customizable PAS behavior, advanced regen features, and easy performance adjustments on the road. In this arrangement, all throttle, ebrake, and PAS or torque sensors are plugged in directly to the Cycle Analyst. The Cycle Analyst is responsible for determining the desired ebike behavior and sending a suitable throttle command to the controller.

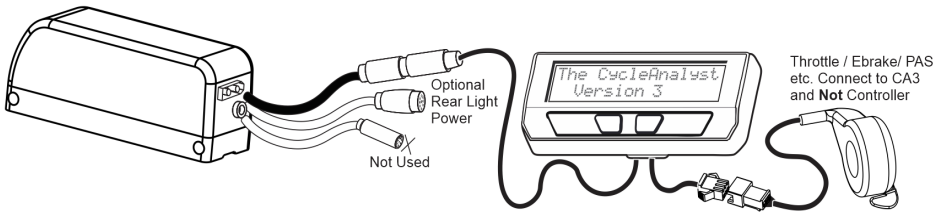

The 6 pin PAS plug of the controller is typically not used in this arrangement except as a possible Fwd/Rev input source. The 9 pin Mains cable either can be left unterminated, or it can be used as a power tap for running rear lights, using a 9 to 2 pin power adapter cable.

3.2 3rd Party Display Hookup

The Phaserunner V6 can be used with certain third party displays (from King Meter, Star-Union, Bafang etc.) that communicate using the KM5s and other supported digital protocols. This is achieved with a 9 pin Mains cable harness which splits out the 9 signals into separate plugs for throttle, display, ebrakes, and front light, along with an (optional) PAS or Torque sensor hooked up to the 6 pin PAS plug as well.

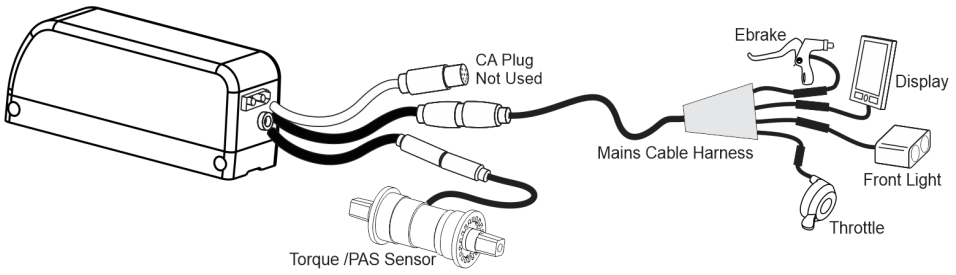

All the key control signals (throttle, ebrake, PAS/Torque) go directly to the Phaserunner V6 and not the display, so additional controller parameters must be set up to achieve desired control response. The display has the on/off power control and up/down settings to set the assist level, but otherwise plays a passive role in the actual system behavior.

In this wiring approach, the WP8 Cycle Analyst plug is not needed, but it can be used as a convenient tap point to power a rear bike light as well.

At present Grin only provides support for this third-party display hookup to OEM customers, and does not offer support or the components for this at the retail level. Configuration and additional controller settings will be detailed in a separate document to this manual.

3.3 Headless System

Finally, the Phaserunner V6 can be run with only a throttle on the Mains plug, or a PAS / Torque sensor plugged into the 6 pin PAS plug. In these arrangements, it is essential to wire up the on/off power switch on either the WP8 plug or the Mains connector for the controller to turn on, as outlined in Section 6.1.

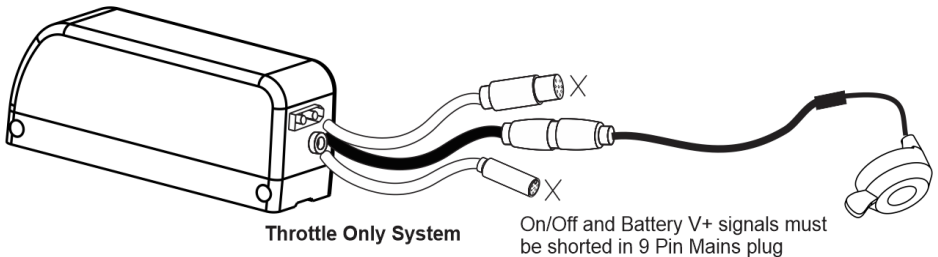

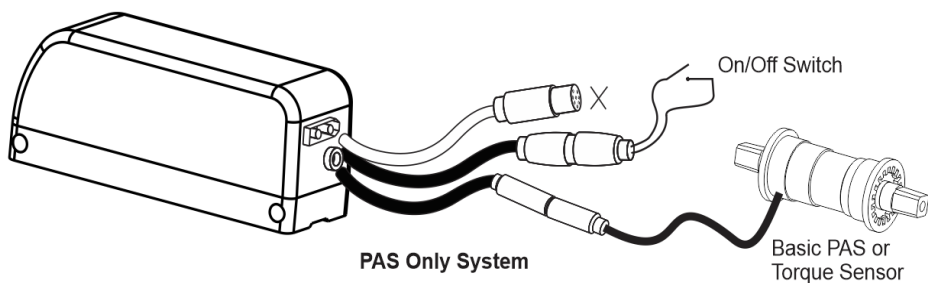

This minimal approach with a PAS sensor does not provide for any means to adjust the assist level outside of reprogramming the controller, and for that reason has limited usefulness. A display unit with up/down buttons is required in order to vary the amount of assist while riding.

4 Controller Mounting

The Phaserunner is designed to be narrow in width and has a channel down the back of the heatsink so that it can be strapped to your bicycle tubing with a pair of cable ties. When mounted externally like this, the controller is exposed to abundant air flow for cooling.

If you want to install the controller inside a vehicle chassis, then the aluminum heatsink should be bolted directly to a metal plate via the 4 mounting holes in order to help with heat dissipation. Otherwise it will be more prone to overheating and going into thermal rollback at high currents.

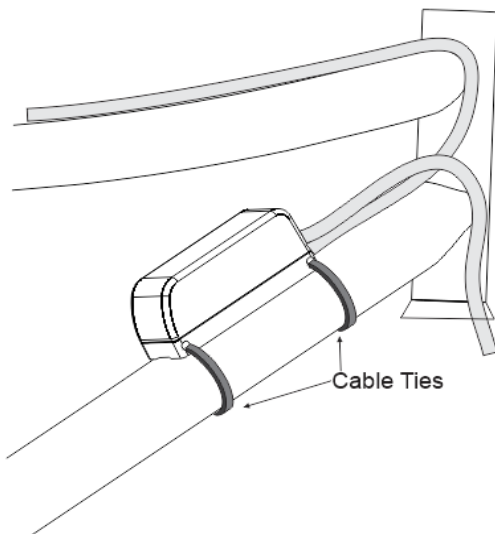

If the controller is running at full 90A and is mounted to a bike tube exposed to airflow, it will hit thermal rollback after 1-2 minute and then settle to ~50 amps of steady state phase current. When bolted to a large external heatsink, the thermal rollback at full current will take longer to kick in (4-6 minutes) and will level off at around 70 amps of phase current.

5 Parameter Tuning

If you purchased the Phaserunner V6 as part of a complete conversion kit that includes a battery, a motor, and so on, the controller should be pre-configured and no tuning of the parameters should be necessary. This section can be skipped entirely.

If you bought the Phaserunner V6 separately, or are changing your set-up, you should configure the controller to your motor and battery pack once it is installed and connected on your bike. You will need a computer, a TTL-USB programming cable, and the **V1.8 or later Phaserunner Software Suite**. The V1.7 and earlier software releases will give an “unrecognized device” error message.

This software is available for Linux, Windows, MacOS and Android from our webpage:

<http://www.ebikes.ca/product-info/phaserunner.html>

Please Note: When configuring your Phaserunner V6 via the software suite, it is essential that your bike is propped up so that the powered wheel can rotate freely, both forwards and backwards. With a rear hub motor, also ensure that the cranks can rotate freely.

With the Phaserunner V6 powered on, plug in the TTL->USB cable from your computer to the device. After launching the *Phaserunner* software, select the COM port associated with the USB cable and you should see “*Phaserunner V6 is connected*” on the top.

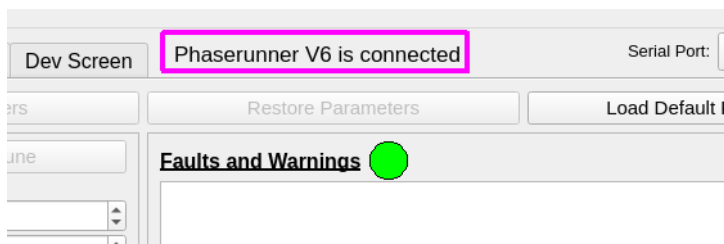

If you see “*Controller is not connected,*” check that the selected serial port is correct and that the USB->TTL device shows up in your device manager as a COM port (Windows), ttyUSB (Linux), or cu.usbserial (MacOS).

If your system does not recognize the USB serial adapter, or has frequent COM timeouts, then you may need to download and install the latest virtual COM port drivers directly from FTDI: <http://www.ftdichip.com/Drivers/VCP.htm>

During the setup process we recommend having the controller powered by a battery pack and not a general power supply, as electrical noise from power supplies can interfere with stable communication.

5.1 Importing Default Motor Parameters

The *Phaserunner Software Suite* comes equipped with default settings for many common motors. With your Phaserunner V6 connected, click on “Load Default Parameters” and select your motor’s manufacturer and model number from the new window. Clicking on “Apply” will return you to the “Basic Setup” tab with all the motor’s parameter fields populated to their correct values.

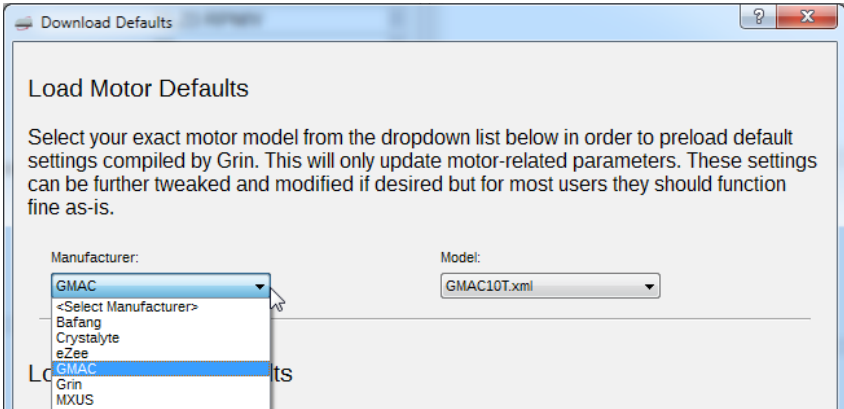

Install these new settings to the Phaserunner V6 via the “Save Parameters” button.

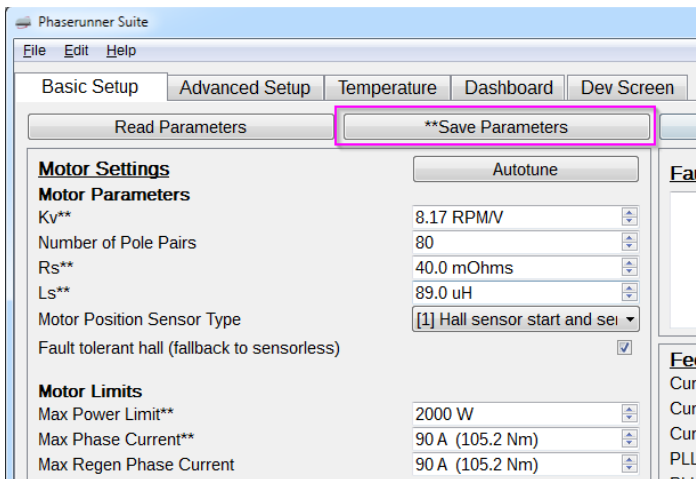

Apply some throttle and your motor should run smoothly. If it does, you can now skip over the “Motor Autotune” section, and continue with “Battery Limits.”

If your motor is not listed on the “Import Defaults” window, try choosing “Download Latest Defaults from Grin” and follow the prompts. If your motor model is still not listed, proceed to the “Motor Autotune” section that follows.

5.2 Motor Autotune

Basic Setup tab

The Autotune routine can automatically detect motor parameters like the motor speed constant (kV), resistance of one motor phase to neutral (Rs), and the inductance of motor phase to neutral (Ls).

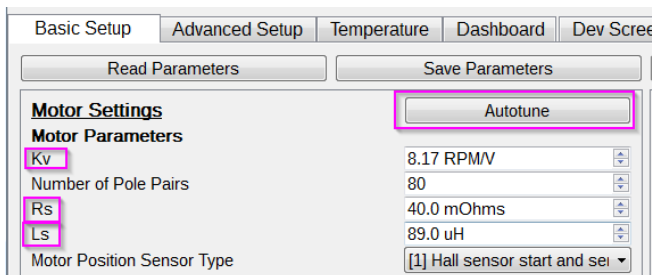

The start of the Autotune process asks for your best guess of the motor’s kV in rpm/V, as well as the number of pole pairs in the motor. The firmware uses these initial parameters for determining the test current frequency.

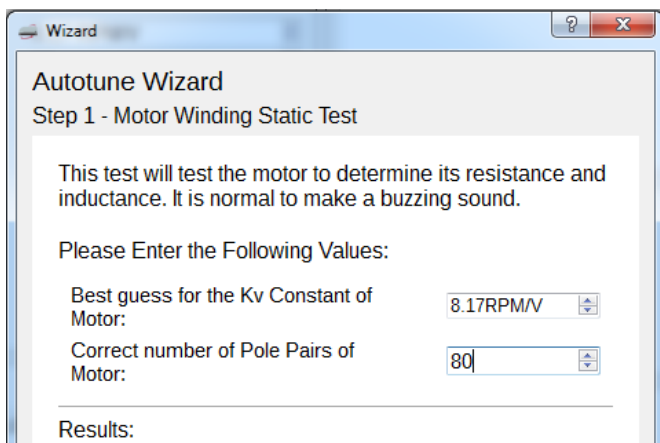

The Autotune routine will usually work fine even if your initial guess for the kV value is incorrect. Most ebike hub motors fall within 7-12 rpm/V and an initial guess of 10 will usually work.

The effective pole pairs is a count of how many electrical cycles corresponds to one mechanical revolution of the motor and must be set correctly. The Phaserunner V6 needs this information to correlate it's electrical output frequency with the wheel speed. In a direct drive (DD) motor, it is the number of magnet pairs in the rotor, while in a geared motor you need to multiply the magnet pairs by its gear ratio. The following table lists the effective pole pairs for many common motor series.

Table 1: Effective Pole Pairs of Common DD and Geared Hub Motors

Motor Family	# Pole Pairs
Crystalyte 400, Wilderness Energy	8
BionX PL350	11
Crystalyte 5300, 5400	12
TDCM IGH, TSM-A5	16
Crysatlyte NSM, SAW	20
Grin All Axle, Crysatlyte H, Nine Continent, MXUS and Other 205mm DD Motors	23
Magic Pie 3, FH/RH212	26
Bafang BPM, Bafang CST	40
Bafang G01, MXUS XF07	44
Bafang G02, G60, G62	50
Shengyi SX1/SX2	72
eZee, BMC, MAC, Puma, GMAC	80
Bafang G310, G311	88
Bafang G370	112

For motors not listed, either open the motor to count the magnets pairs (and gear ratio), or count the number of Hall cycles that take place when you manually turn the wheel backwards one revolution. You can monitor the number of Hall transitions via the “Dashboard” tab of the software suite.

Once the “kV” and the “Number of Pole Pair” values are entered, launch the “Static Test.” This test will produce three short buzzing sounds, and determine the inductance and resistance of the motor windings. The resulting values will be shown on the screen.

Next, launch the “Spinning Motor Test” which will cause the motor to rotate at about half speed for 15 seconds. During this test, the controller will determine the actual kV winding constant for the hub, as well as the pinout and timing advance of the Hall sensors if they are present. If the motor spins backwards during this test, check the box “Flip Motor Spin Direction on Next Autotuning?” and relaunch the “Spinning Motor Test.”

During the spinning test, the Phaserunner V6 will start the motor in sensorless mode. If the motor fails to spin and just starts and stutters a few times, first double check your starting values for effective pole pairs and KV. If they are indeed correct, you may need to adjust the sensorless starting parameters as described in section 5.5, “Tuning the Sensorless Self Start,” until the motor is spinning steadily. If the spinning test detects a valid Hall sequence, the final screen will show the hall offset, and that the “Position Sensor Type” is “Hall sensor start and sensorless run.”

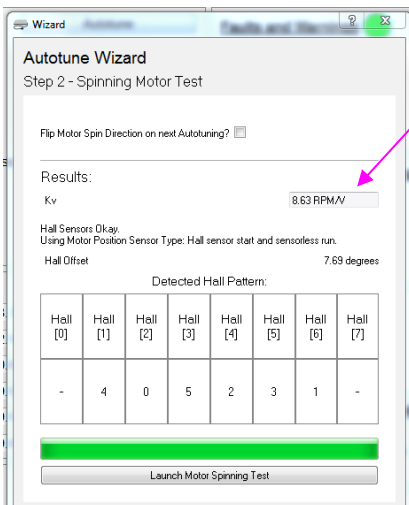
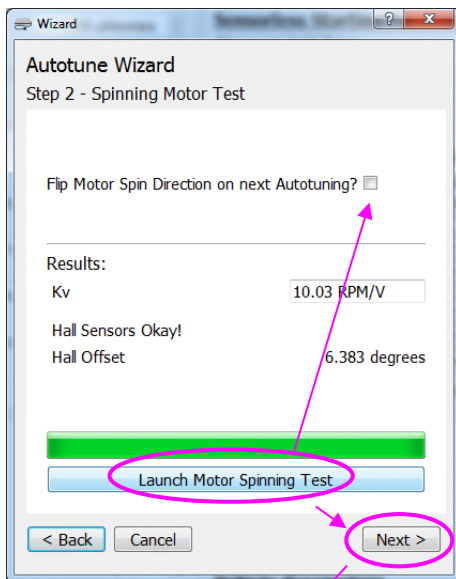
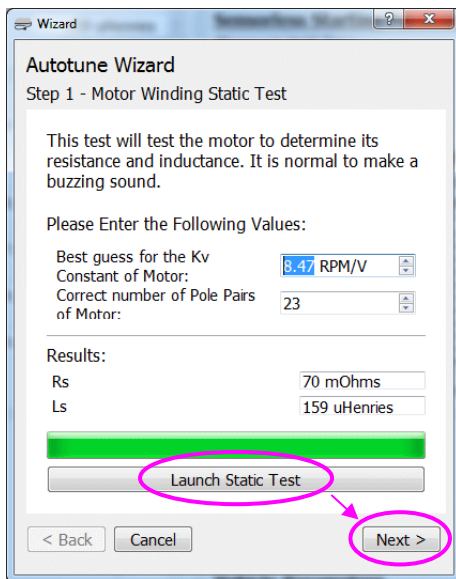

5.3 Battery Limits

Basic Setup tab

With the controller mapped to your motor and spinning correctly, you should now set the battery voltage and current settings to appropriate values for your pack.

Battery Limits	
Max Battery Current	30.0 A
Max Regen Battery Current	15.0 A
Max Regen Voltage (End)**	55.0 V
Max Regen Voltage (Start)**	54.5 V
Low Voltage Cutoff (Start)**	39.0 V
Low Voltage Cutoff (End)**	38.0 V

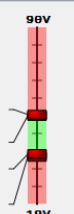

Set “Max Battery Current” to a value that is equal to or less than the battery’s discharge current rating. Higher battery currents will result in more power, but can also stress the battery cells, resulting in shorter battery life. Excessively high values can cause the BMS circuit to trip, shutting down the pack.

We recommend setting “Max Regen Voltage (Start)” to the same value as the full charge voltage of your battery, with the “Max Regen Voltage (End)” to about 0.5V higher than full charge. This will ensure you can do regen even with a mostly charged battery.

The “Low Voltage Cutoff (Start)” and “Low Voltage Cutoff (End)” values can be set just above the BMS cutoff point of your battery. If you are using a V3 Cycle Analyst, we recommend leaving these values at the default 19.5/19.0 volts and use the CA3’s low voltage cutoff feature instead. That way you can change the cutoff voltage without a computer if you ever need to swap batteries.

If you are setting up a system with regenerative braking and have a BMS circuit that shuts off if it detects excessive charge current, you will also need to further limit the “Maximum Regen Battery Current” to a value lower than the BMS trip current. Otherwise it’s not usually an issue with modern lithium cells to have short duration peak regen current levels of 2C, ie double the battery amp-hours.

5.4 Motor Phase Current and Power Settings

Basic Setup tab

In addition to regulating the current flowing in and out of the battery pack, the Phaserunner V6 can independently control the maximum phase currents that flow to and from the motor. It is the motor phase current that both generates torque and causes the motor windings to heat up. At low motor speeds this

phase current can be several times higher than the battery current you see on a Cycle Analyst.

Motor Limits	
Max Power Limit	2000 W
Max Phase Current**	90 A (105.2 Nm)
Max Regen Phase Current**	60 A (70.2 Nm)

The “Max Power Limit” sets an upper limit on the total watts that will be allowed to flow into the hub motor. This value has a similar effect to a battery current limit, but it is dependent on voltage. A value of 2000 Watts will limit battery current to 27 amps with a 72V pack, while allowing over 40 amps with a 48V pack.

“Max Phase Current” determines the peak amps, and hence torque, put through the motor while accelerating at full throttle assuming no other limits are reached.

The “Max Regen Phase Current” value directly sets the peak braking torque of the motor at full regen. If you want a strong braking effect, then set this to the same value as the forward phase current limit. If the maximum braking force is too intense, then reduce its value.

The following graph illustrates the interplay between motor phase current, battery current, and motor output power for a typical setup. When riding at full throttle, low speeds will be phase current limited, medium speeds will be battery current limited, and high speeds will be limited by the voltage of your battery pack.

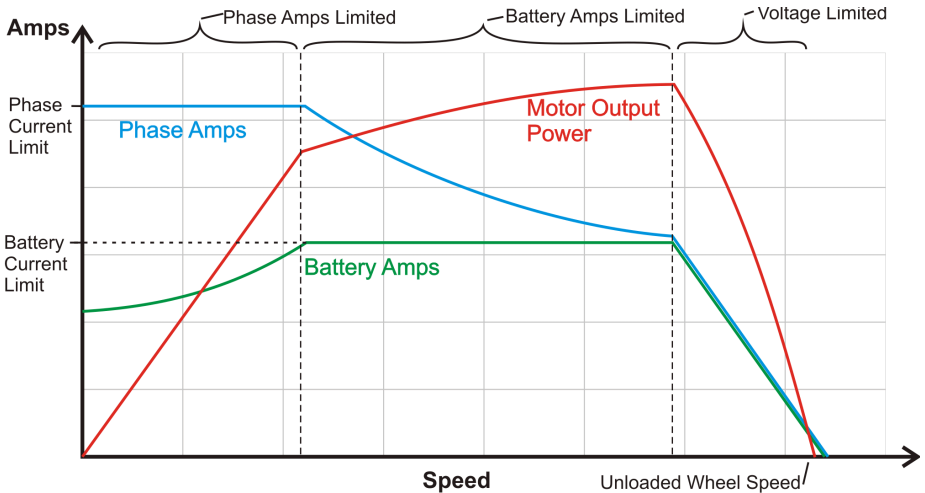

5.5 Tuning the Sensorless Self Start

Advanced Setup

If you are running in sensorless mode, then you may need to tweak the sensorless self start behaviour.

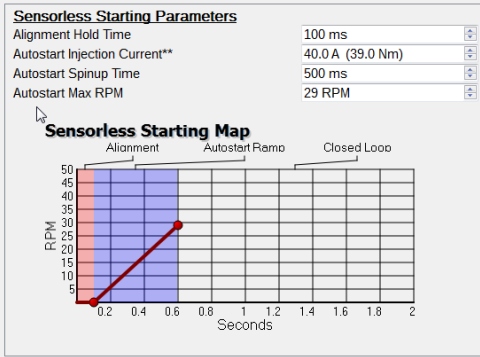

When a brushless motor is run without Hall sensors and started from a complete stop, the motor controller attempts to ramp up the motor's rpm to a minimum speed so that it can latch onto the rotation (closed loop).

It does this by first injecting a static current into the phase windings to orient the motor into a known position. The controller then rotates this field faster and faster until reaching the "Autostart Max RPM" value.

As initial values, set the "Autostart Injection Current" to half your maximum phase current, an "Autostart Max RPM" between 5% to 10% of the running motor rpm, and an "Autostart Spinup Time" anywhere from 300 to 1500 milliseconds, depending on how easily the motor can propel the bike up to speed.

On bikes that you pedal to help get you underway, a short 200 to 300 millisecond ramp will often work best, while a much longer ramp is required if you need to start moving without pedaling.

If you feel the motor repeatedly trying to start when applying throttle, the "Autostart Spinup Time" may be too short, or the "Autostart Max RPM" may be too low. You may also generate faults such as "Instantaneous Phase Overcurrent." To correct this particular fault, try increasing either the "Current Regulator Bandwidth" or the "PLL Bandwidth" parameters, or both. These parameters are found under "Feedback Bandwidth Tuning" on the "Basic Setup" tab.

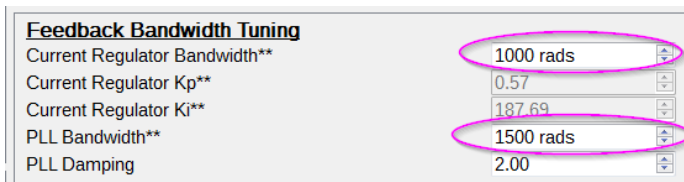

5.6 Throttle and Regen Voltage Maps

Advanced Setup tab

With most ebike controllers, the throttle signal controls the effective voltage and hence unloaded rpm of the motor. With a Phaserunner V6, however, the throttle is directly controlling the motor torque.

If you pick the motor off the ground and give it just a tiny amount of throttle, it will still spin up to full rpm as there is no load on the motor. People sometimes mistake this behavior as an all-or-nothing throttle response. If you apply partial throttle *while riding*, you will get a proportional torque from the motor which will stay constant even as the vehicle speeds up or slows down. This is different from standard ebike controllers, where the throttle more directly controls motor speed.

By default, the Phaserunner V6 is configured so that active throttle starts at 1.2V, and full throttle is reached at 3.5V, which is broadly compatible with Hall Effect ebike throttles. The same signal for the throttle is also used to control regenerative braking (see Section 6.1 Turning the Controller On and Off).

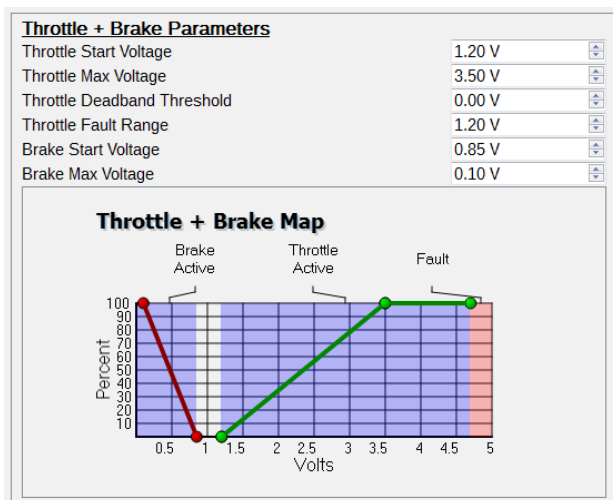

The regen voltage is mapped by default so that regenerative braking starts at 0.8V and reaches maximum intensity at 0.0V. This way there is no overlap between the throttle region and the braking region and a single wire can control both ranges.

5.7 Field Weakening for Speed Boost

Basic Setup tab

The Phaserunner V6 can boost the top speed of your motor beyond what is normally possible from your battery voltage. This is accomplished by injecting a field weakening current in advance of the torque producing current.



The amount of speed boost received for a given field weakening current will depend on the winding characteristics of your particular motor. A trial and error approach is recommended, increasing in small increments until the desired top speed is achieved.

Increasing a motor's top speed in this way is less efficient than using a higher voltage pack or a faster motor winding, but for a speed boost of 15% to 20%, the additional losses are quite reasonable.

The following graph shows a large direct drive hub motor's rpm as a function of field weakening current. The upper black line is the motor's measured rpm, while the initially lower yellow line is the no-load current draw, reflecting the amount of extra power lost due to field weakening. We can see that at 20 amps of field weakening, the motor speed increases from 310 rpm to 380 rpm, while the no load current draw is still just under 3 amps.

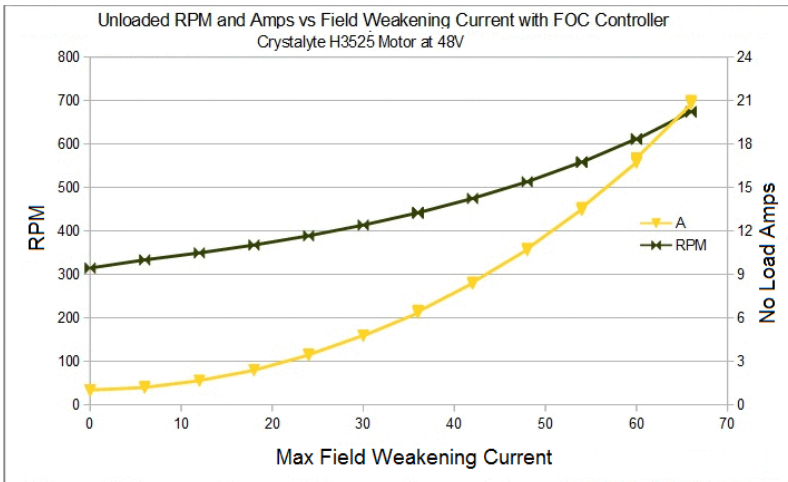

5.8 Virtual Electronic Freewheeling

Dashboard/Basic Setup tabs

The Phaserunner V6 controller can be set to inject a small amount of current into the motor, even when the throttle is off. When properly tuned, this current injection can overcome the drag torque present in hub motors capable of regenerative braking, allowing them to spin freely when pedaling without any throttle.

Virtual Electronic Freewheeling	
Enable Virtual Freewheeling**	<input checked="" type="checkbox"/>
Electronic Freewheeling Current**	3.01 A (2.9 Nm) <input type="text"/>
Motor Stall Timeout	100 ms <input type="text"/>

To setup this feature, we recommend first going to the “Dashboard” tab. With the system running under throttle with no load on the motor, note the “Motor Current” value.

Basic Setup	Advanced Setup	Temperature	Dashboard	Dev Sc
Battery Voltage	36.28 V	Left Axis <input type="text"/>		
Battery Current	2.85 A	Left Axis <input type="text"/>		
Motor Current	3.41 A	Don't Plot <input type="text"/>		

Navigate back to the “Basic Setup” tab, check “Enable Virtual Freewheeling,” and set “Electronic Freewheeling Current” to a value slightly less than that of the observed unloaded motor current. The “Motor Stall Timeout” setting determines when this injection current will stop once the motor comes to a stop.

Once the values for “Virtual Electronic Freewheeling” are set, the controller will draw about 10 to 40 watts in order to overcome the motor’s drag. Regenerative braking will usually recapture more energy than is used by the injection current.

Users of mid-drive motors can also use this feature to keep the drive train always engaged, eliminating windup delay and harsh clutch engagement when throttle is applied and the motor comes up to speed.

5.9 Motor Temperature Sensing

Temperature Setup tab

The Phaserunner V6 has the ability to sense motor temperature and prevent the motor from overheating via thermal rollback. An entire tab in the software suite is dedicated to the motor thermal rollback settings. A six point table maps the voltage that corresponds to the temperatures of 0°, 25°, 50°, 75°, 100°, and

125°C. For convenience we have provided a drop-down selection of the three thermistor types commonly used on hub motors. For other temperature devices, these values can also be input manually instead.

The screenshot shows the software interface with the following sections:

- Motor Temperature Parameters:** Includes a checkbox for "Motor Temperature Sensing Enable**" which is checked. Text explains that these parameters are for motors with a built-in temperature sensor.
- Temperature Limits:**
 - Motor Over Temperature Trip Threshold: 120 deg C
 - Motor Foldback Starting Temperature: 100 deg C
 - Motor Foldback Ending Temperature: 120 deg C
- Temperature Readings:**
 - Motor Temperature: 0 deg C
 - Motor Temperature Sensor Voltage: 0.00 V
 - Refresh Motor Temperature Readings button
- Load Temperature Sensor Presets:** A dropdown menu is open showing options: "10k ntc, B=3450", "10k ntc, B=3950", "10k ntc, B=3450", and "10k ntc, Bafang Current Values". Below the menu are input fields for temperature voltages at 0C, 25C, 50C, 75C, 100C, and 125C, with values ranging from 1.374 V to 0.492 V.
- Temperature Voltage Map:** A line graph showing Voltage (V) on the y-axis (0 to 5) versus Degrees Celsius on the x-axis (0 to 125). The graph shows a downward-sloping curve representing the temperature-voltage relationship.

This feature allows for safe operation of motors even without a V3 Cycle Analyst. If you have a Cycle Analyst we recommend using the CA3's thermal rollback features and leaving the controller's rollback unchecked.

6 Additional Details:

6.1 Turning the Controller On and Off

In order to power on, the Phaserunner V6's on/off wire must be shorted to battery V+, through either the WP8 plug or the 9 pin mains plug. This is accomplished either with a Cycle Analyst plugged into the WP8 plug, or one of the 9 pin mains cable options on the 9 pin plug. If battery power is applied without the on/off input connected to V+, the controller won't turn on or connect to a computer.

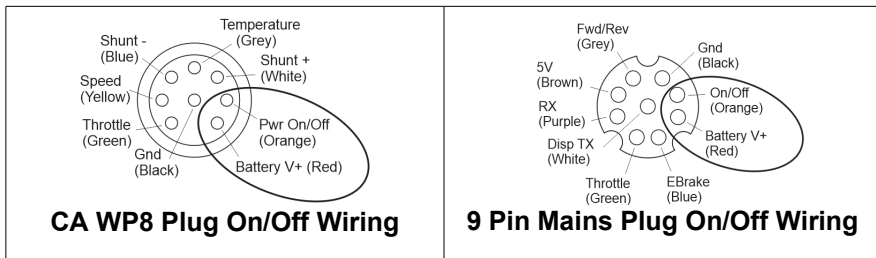

6.2 Signal Mapping

The Phaserunner V6 uses the analog Brake 1 signal input as both the throttle and regenerative brake signal source. This differs from the earlier Phaserunner controllers which used separate signals for “Throttle Sensor Source” and “Regen Brake Source”, which were then shorted externally in the connector wiring.

The nominal 'throttle' input of the controller is now mapped as a torque sensor input, while inputs that were previously unused are now being used.

 Custom Parameter Edit

Addr: 249	Regen Brake Source	[1]Analog Input 2 (Brk1)	X
Addr: 247	Throttle Sensor Source	[1]Analog Input 2 (Brk1)	X
Addr: 242	Torque Sensor Voltage Source	[0]Analog Input 1 (Thrt)	X
Addr: 193	Wheel Speed Sensor Source	[1]Analog Input 3 (Brk2)	X
Addr: 137	Motor Temperature Source	[2]Analog Input 4 (BMS)	X

These settings can be seen by going *Edit* → *Edit Parameters* as shown above. The difference between earlier Phaserunner devices and Phaserunner V6 are summarized in the table below:

Input Source	Phaserunner (V1-V3)	Phaserunner (V6)
Throttle Source (CA)	Analog Input 1 (Thrt)	Analog Input 2 (Brk1)
Throttle Source (OEM)	N/A	Analog Input 1 (Thrt) or 2 (Brk1)
Regen Brake Source	Analog Input 3 (Brk2)	Analog Input 2 (Brk1)
Torque Sensor Source	N/A	Analog Input 1 (Thrt)
Motor Temperature	N/A	Analog Input 4 (Mtr temperature)
PAS	N/A	Digital Input 2 (PFS)
Wheel Speed Sensor	Hall A	Analog Input 3 (Brk2)
Fwd/Rev	Digital Input 1 (Cruise)	Digital Input 1 (Cruise)

These changes were necessary to fully support the independent use of torque sensors and throttles on the same controller. As a result, if full parameter settings saved from a Phaserunner V3 or older device are then imported to the

Phaserunner V6 or vice versa, the controller is unlikely to function until the signal mapping is corrected as per the table above.

6.3 Reverse Mode

The signal *PAS 2* used in the 6 pin PAS plug is electrically equivalent to the *FWD/REV* pin in the Main plug. This input is by default configured as a reverse switch input by enabling “Reverse on Cruise” for applications that require direction reversal. When using quadrature (2 wire) PAS sensors plugged into the PAS plug, this must be unchecked.

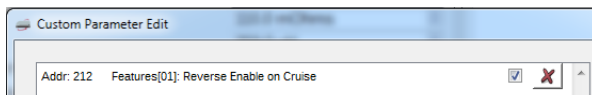

6.4 Wheel Speed Sensing

The Phaserunner V6 will automatically select the source of the wheel speed signal for vehicle speed measurement. If there are speed pulses present on the wheel speed sensor pin then these will be mapped automatically to the Cycle Analyst plug. If no speed pulses are detected even after the motor is spinning, then the motor Hall signals will get fed to the speed signal input instead.

6.5 Combined Temp / Speed Signal

The Phaserunner V6 can also work with combined temperature and speed signals that are present on the temperature input pin. If there are no speed pulses present on the Wheel Speed signal, and the temperature signal periodically drops to 0V, then the Phaserunner V6 will treat those 0V pulses as speed signals to track wheel rotation.

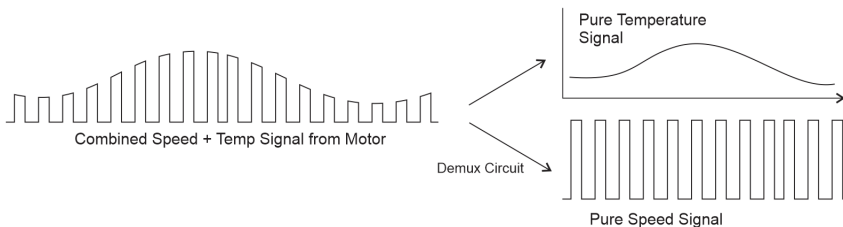

6.6 Independent Regenerative Braking

The Phaserunner V6 by default has both the throttle signal source and the regen brake signal source coming from the same line, Analog Input 2, which floats at 1V when disconnected. This allows for a single wire to control both power and braking. The signal can be shorted to ground via an ebrake lever to achieve maximum regen braking.

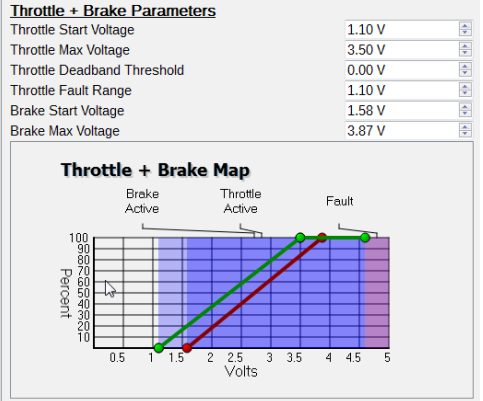
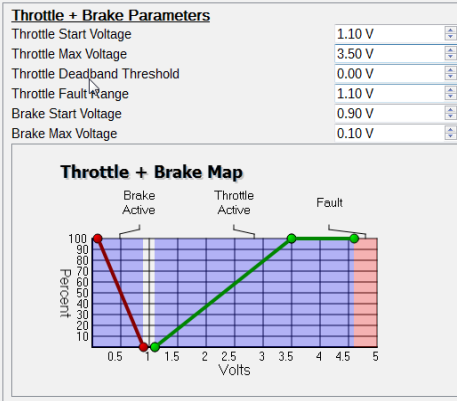

Throttle + Brake Map for Combined Signal

Example for Independent Throttle and Brake

If completely independent throttle and regen brake signals are desired, then the throttle signal source can be changed to Analog Input 1. Separate wires can be used to control braking versus throttling.

7 Cycle Analyst Settings

Current Sensing [Cal->RShunt]

The Phaserunner V6 uses a 1.00 mΩ +/- 0.02 mΩ shunt resistor for current sensing. The exact calibrated value is laser engraved on the controller heatsink. In order to have the most accurate readout of battery current, ensure that the Cycle Analyst's "RShunt" value is set to match this.

Throttle Out [ThrO->Up/Down Rate] [SLim->Int,D,PSGain]

Because the Phaserunner V6 uses a torque throttle rather than a voltage throttle, the entire throttle voltage range is always active. Optimal settings for the throttle output on a V3 Cycle Analyst will differ than that for generic ebike controllers.

The ramp up and ramp down rates as well as the feedback gain settings (AGain, WGain, IntSGain, DSGain, PSGain) can be set much higher than with a conventional controller with a voltage throttle. These will need to be tweaked for your particular motor, but good starting values are:

- Ramp Up: 6 V/sec
- WGain: 50-100
- AGain: 300-400
- IntSGain: 100-150
- DSGain: 600-800
- PSGain: 2-3 V/kph

8 LED Flash Codes

The embedded red LED inside the controller provides a useful status indicator. It will flash according to the following table if the controller detects any faults. For example, for a 2-4 flash code, the LED will blink twice in quick succession, followed by a short pause, then four more blinks, followed by a long pause, at which point the flash code will repeat. Some faults will clear automatically once the condition clears, such as “Throttle Voltage Outside of Range,” while other faults may require turning the controller off and on.

Table 2: LED Fault Flash Codes

1-1	Controller Over Voltage
1-2	Phase Over Current
1-3	Current Sensor Calibration
1-4	Current Sensor Over Current
1-5	Controller Over Temperature
1-6	Motor Hall Sensor Fault
1-7	Controller Under Voltage
1-8	POST Static Gate Test Outside Range
2-1	Network Communications Timeout
2-2	Instantaneous Phase Over Current
2-3	Motor Over Temperature
2-4	Throttle Voltage Outside of Range
2-5	Instantaneous Controller Over Voltage
2-6	Internal Error
2-7	POST Dynamic Gate Test Outside Range
2-8	Instantaneous Controller Under Voltage
3-1	Parameter CRC Error
3-2	Current Scaling Error
3-3	Voltage Scaling Error
3-4	Headlight Under Voltage
3-5	Torque Sensor
3-6	CAN Bus
3-7	Hall Stall
4-1	Parameter2CRC

The LED may also flash several different warning codes. These warnings do not stop the controller from running and will appear as various limits are reached in normal operation, they are not usually a cause for any concern.

Table 3: LED Warning Flash Codes

5-1	Communication Timeout
5-2	Hall Sensor
5-3	Hall Stall
5-4	Wheel Speed Sensor
5-5	CAN Bus
5-6	Hall Illegal Sector
5-7	Hall Illegal Transition
5-8	Low Voltage Rollback Active
6-1	Max Regen Voltage Rollback Active
6-2	Motor Overtemperature Rollback
6-3	Controller Overtemperature Rollback
6-4	Low SOC Foldback
6-5	Hi SOC Foldback
6-6	I2tFLDBK
6-7	Reserved
6-8	Throttle fault converted to warning

When corresponding with Grin about Phaserunner troubleshooting, note in advance if the LED is flashing when the fault occurs, and include the flash code in the correspondence.

9 Specifications

9.1.1 Electrical

Peak Battery Current	Programmable up to 90A*, practical maximum is around 40A due to phase current limits.
Peak Phase Current	Programmable up to 90A*
Peak Regen Phase Current	Programmable up to 90A*
Continuous Phase Current	Approximately 55A at thermal rollback, varies with air flow and heat sinking
Phase Current Rollback Temp	90°C Internal Temp (casing ~70°C)
Max Battery Voltage	87V (20s Lithium, 24s LiFePO4)
Min Battery Voltage	19V (6s Lithium, 7s LiFePO4)
eRPM Limit	Not recommended above 60,000 eRPM, though it will continue to function beyond this.
RShunt for Cycle Analyst	1.00 mΩ

*Thermal rollback will typically kick in after 1 to 2 minutes of peak phase current, and then phase current will automatically reduce to maintain controller rollback temperature.

9.1.2 Mechanical

Dimensions LxWxH	99 x 35 x 40 mm
Weight	0.20 / 0.25kg (MT / L10)
Signal Cable Length	10cm to Connector End
Motor Cable Length	53cm to Connector End
Waterproofing	Fully Potted Circuitry, IP rated signal plugs

